

**SERIES FLUSH GLAZE
for SINGLE GLAZING
45mm (1-3/4") X 114mm (4-1/2")****I. GENERAL****Scope of Work**

Furnish materials, labour, plant, equipment, related items and services necessary for the supply, complete fabrication and installation of glazed wall aluminum framing as shown on the drawings, required by job conditions and specified herein.

Work Not Included

Structural support for the system, steel and other embeds in concrete or masonry, interior moulding, closure or trim as well as flashing unless specifically detailed and called out as such.
(Specifier List of Other Exclusions)

Related Work Specified Elsewhere (Specifier List)**Submittals****Shop Drawings**

Prior to fabrication submit shop drawings showing frame elevations, full size details as far as practical, all dimensions, coordination with related work, provision for thermal expansion and main structure deformations and tolerances, sealing and caulking joints and their sizes, material and installation notes as well as all necessary references to local Building Code requirements.

Samples

Before any work is fabricated, all requested representative and properly labeled samples, including specified products with their finishes, shall be submitted to the Architect for his approval.

II. PRODUCTS**Glazing System**

- ° The system must allow for full integration with the building envelope.
- ° Aluminum framing shall be **4500 Series**, as manufactured by **Aluminex**
- ° The system shall be dry-dry, outside-glazed, able to accommodate 6mm / 0.25" single glass where required, others, or any combination of the above, as specified and shown on the architectural drawings.
- ° The nominal profile dimensions shall be 45.5mm/1.75" wide and 114.3mm /4.5" deep appropriate for load and span conditions.
- ° If required, steel reinforcing shall contribute to the glazing system structural capacity.
- ° Glass retention shall be achieved by flush glazing with extruded aluminum exterior glazing stop as for dry-dry gasketing method.
- ° Continuous sill aluminum flashing, with its properly designed end dams, must ensure that all water intrusions are directed to the outside.
- ° Whenever substitute systems and/or products are considered, supporting data must be submitted ten (10) days prior to bid date to allow for valid comparison.

Performance

- ° The minimum requirements shall be based on the following ASTM test standards: E-283 Air Infiltration, E-331 Water Penetration, and E-330 Structural Performance with L/ 175 or 19 mm / 0.75" (whichever is less) deflection limitations.
- ° Seismic movement minimum allowances shall be referred to and follow structural design and requirements of the main structure.

Materials

- ° Extruded aluminum shall be AA 6063 T6, Fy = 170 MPa / 25 KSI, alloy and temper minimum, or other as required by the Code and Standards, able to meet or exceed structural and finishing criteria as specified.
- ° Any defects impairing strength, durability or appearance are not acceptable.
- ° Sufficient strength and size fasteners shall be made of corrosion-resistant and compatible material such as cadmium or zinc plated carbon steel type 400, stainless steel type 300, or aluminum.
- ° Anchoring fastener minimum penetration and location in the main structure materials shall follow manufacturer's specifications.
- ° Dissimilar materials shall be separated with approved bituminous paint or spacers, to prevent any galvanic action (corrosion).
- ° Glazing shall utilize wedge or spline extruded Neoprene, EPDM, or other compatible material, gaskets.
- ° Gasket profiles shall be designed and sized to work with the system and properly serve glazing rabbet assembly.
- ° Setting blocks must be properly sized (L mm = 25 mm / 1" per each 1 m² / 10 ft² of glass, but not less than 100 mm / 4"), placed at 1/4 points, and compatible with the insulating glass sealant.

Finish

All exposed surfaces shall be free from defects, scratches and serious blemishes. Aluminum shall receive one of the following available finishes specified by the Architect:

- i) Standard commercial clear anodic coating integral colour (02).
- ii) Standard commercial dark bronze or black hardcolour anodic coating (04, 05).
- iii) Optional anodic coating finishes are light bronze. -Specifier selection
- iv) Standard baked enamel paint, white, black and Rideau brown colour.
- v) Other paint qualities and colours in baked enamel. -Specifier selection

III. EXECUTION**Fabrication**

- ° Fabricate and assemble in strict accordance with the approved shop drawings and manufacturer's published recommendations.
- ° The System shall allow for outside conventional flush glazing, with glass hard bite not less than 10mm (0.375").
- ° Aluminum profiles shall be connected accurately to each other by anti-corrosive fasteners and sealed properly, presenting air and water tight joints, and providing for resilient glass setting and for thermal expansion.
- ° Entrance and other glazed curtain wall members, wherever applicable, shall be compatible in appearance with the System.
- ° All frames for single acting doors shall include positive weathering barrier.

Installation

- ° Framing shall be installed, secured and glazed by an experienced crew.
- ° Set framing level, plumb, square and aligned with other work, in accordance with approved shop drawings and manufacturer's installation instructions and published glazing standards.
- ° All perimeter joints shall be sealed and caulked with approved sealant materials to ensure a weather-tight installation.

Protection and Cleaning

- ° All work shall be protected against damage during and after installation.
- ° After installation all exposed surfaces shall be cleaned of all contaminants.
- ° The General Contractor is responsible for protection and final cleaning.

4500 SERIES FLUSH GLAZE
for SINGLE GLAZING
45 mm (1.75") X 114 mm (4.5")

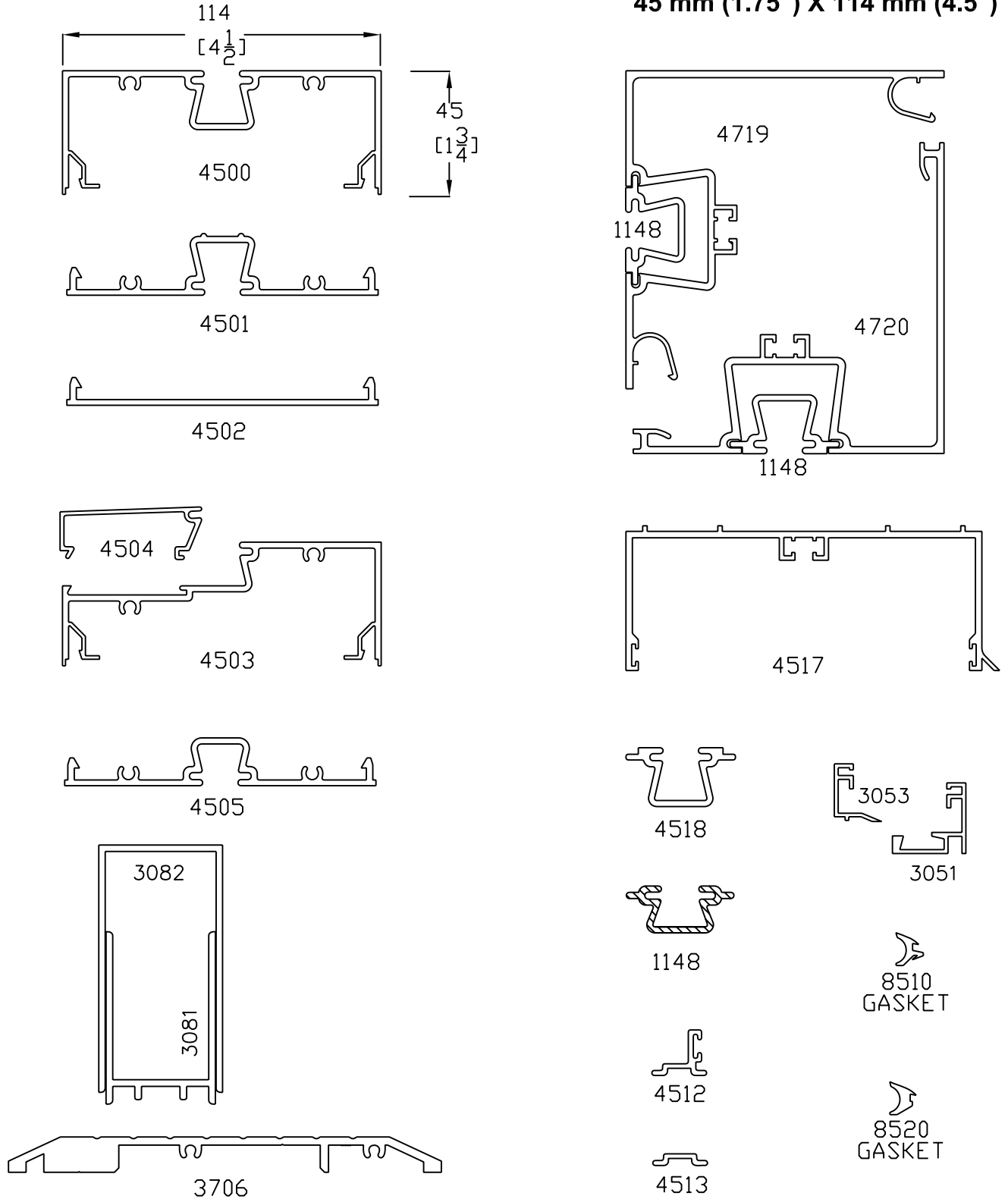

SCALE 1:2

4500 SERIES FLUSH GLAZE

for SINGLE GLAZING
45.5 mm (1.75") X 114.3 mm (4.5")

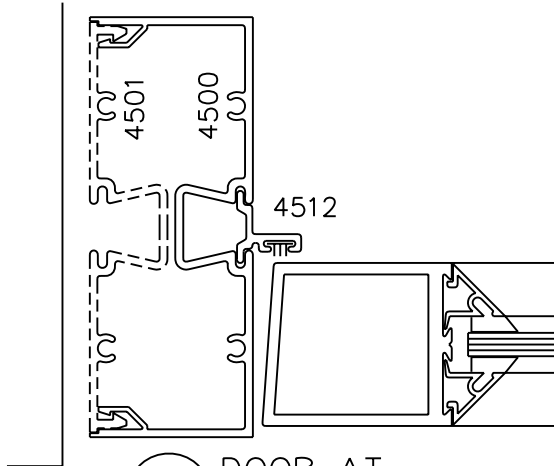
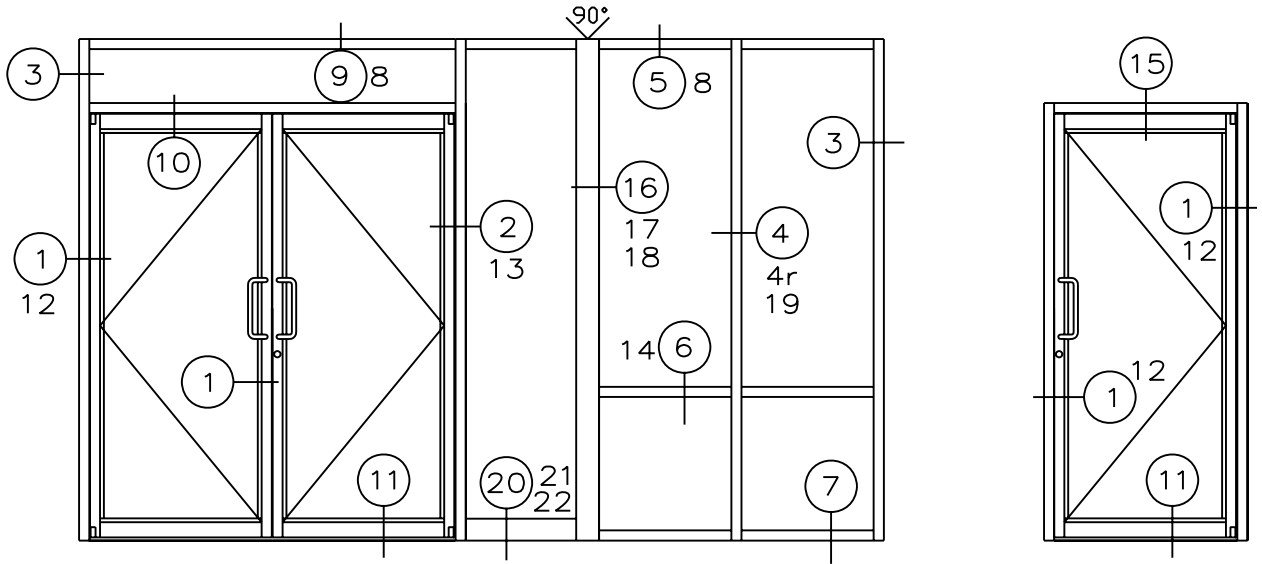

1 DOOR AT JAMB

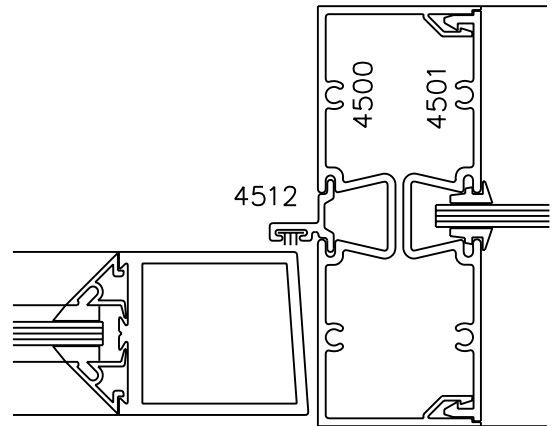

2 DOOR AT MULLION

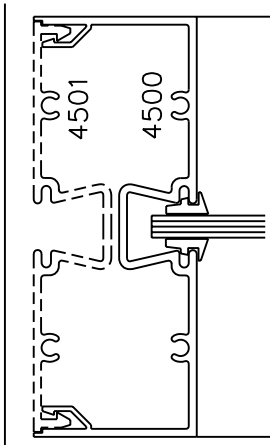

3 JAMB

SCALE 1:2

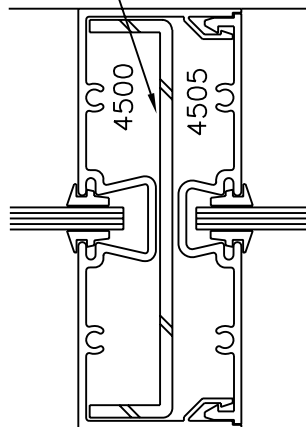

4r COUPLING MULLION FOR REINFORCING

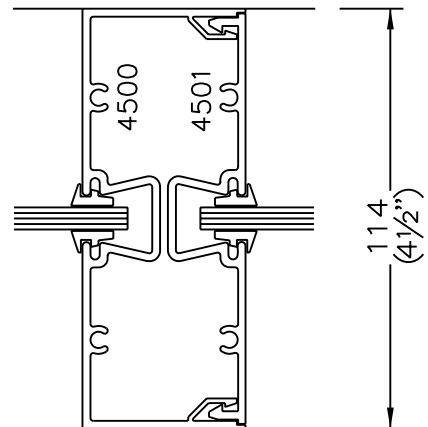

4 COUPLING V. MULLION

4500 SERIES FLUSH GLAZE
for SINGLE GLAZING
45.5 mm (1.75") X 114.3 mm (4.5")

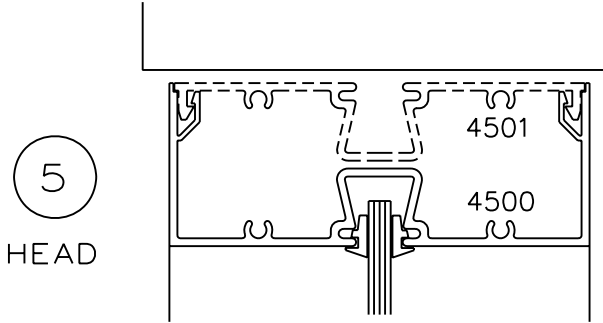

5
HEAD

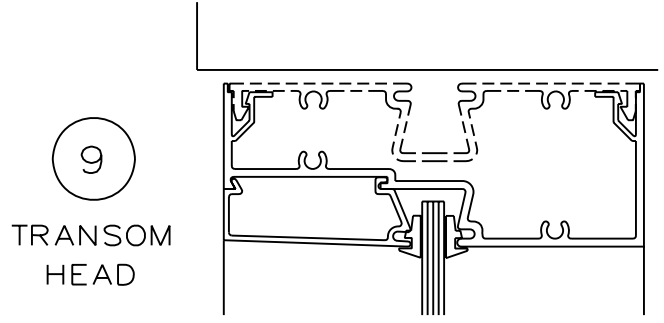

9
TRANSOM
HEAD

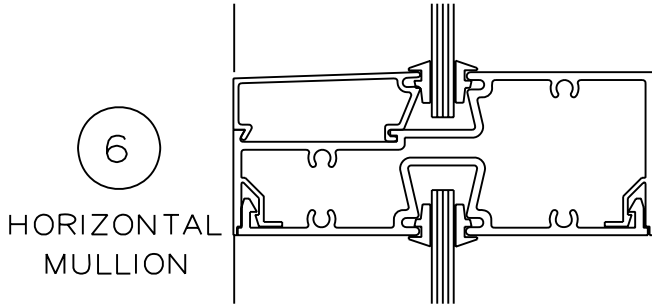

6
HORIZONTAL
MULLION

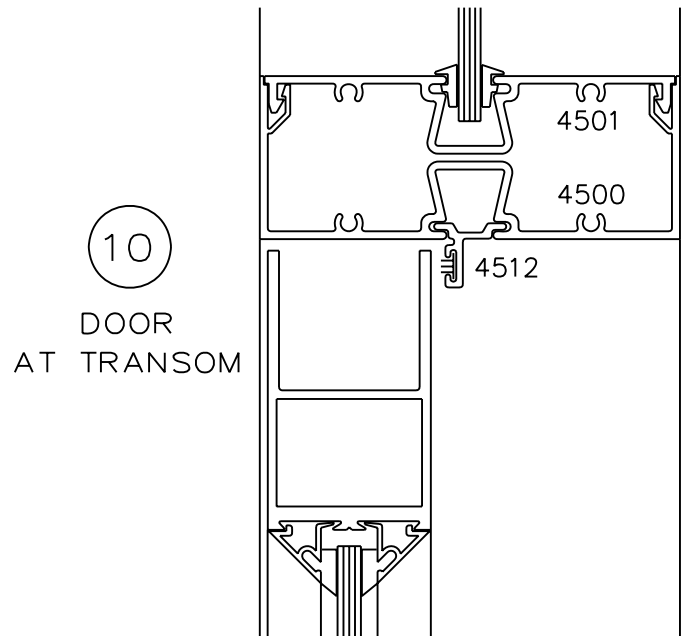

10
DOOR
AT TRANSOM

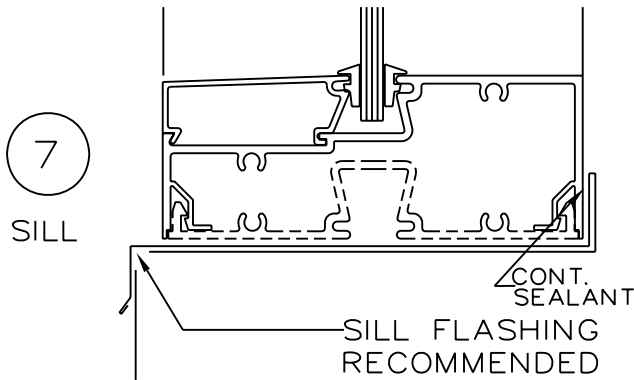

7
SILL

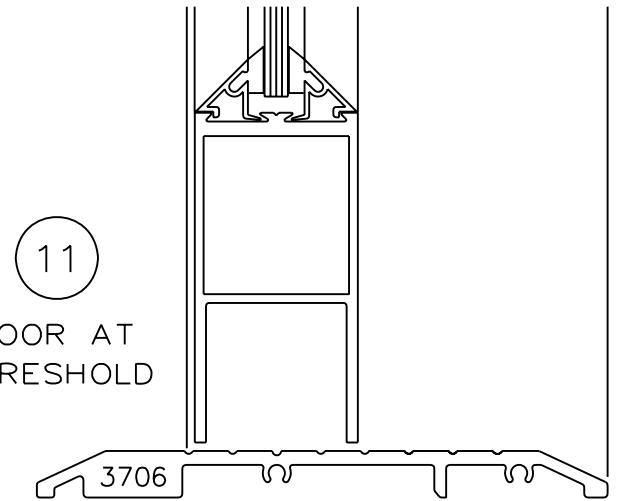

11
DOOR AT
THRESHOLD

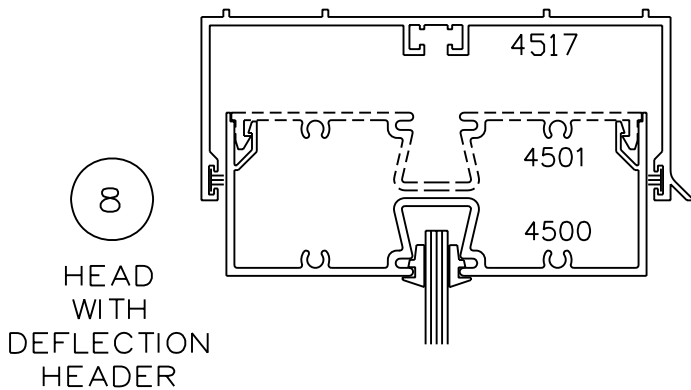

8
HEAD
WITH
DEFLECTION
HEADER

SCALE 1:2

4500 SERIES FLUSH GLAZE
for SINGLE GLAZING
45.5 mm (1.75") X 114.3 mm (4.5")

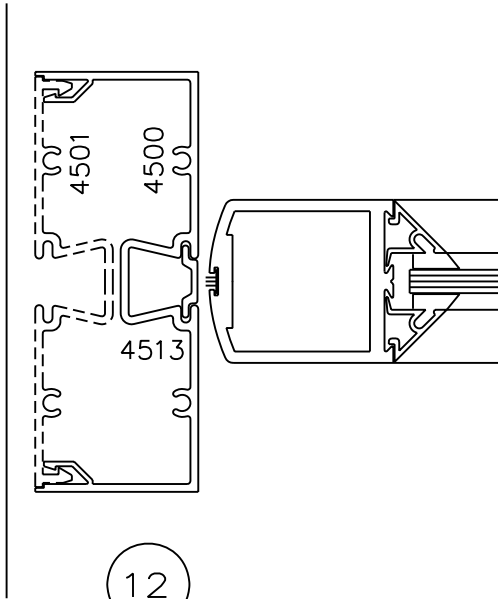

12

DOOR AT
JAMB

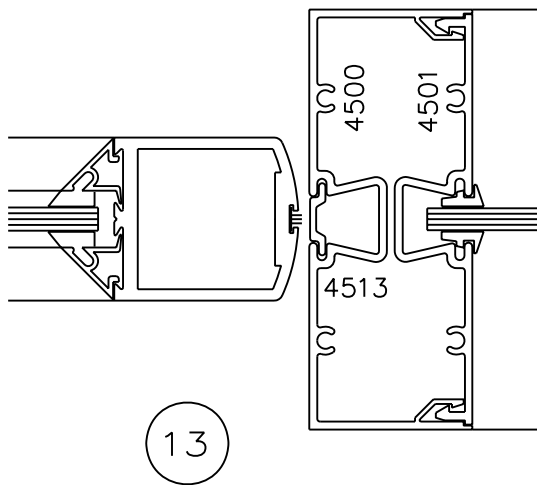

13

DOOR AT
MULLION

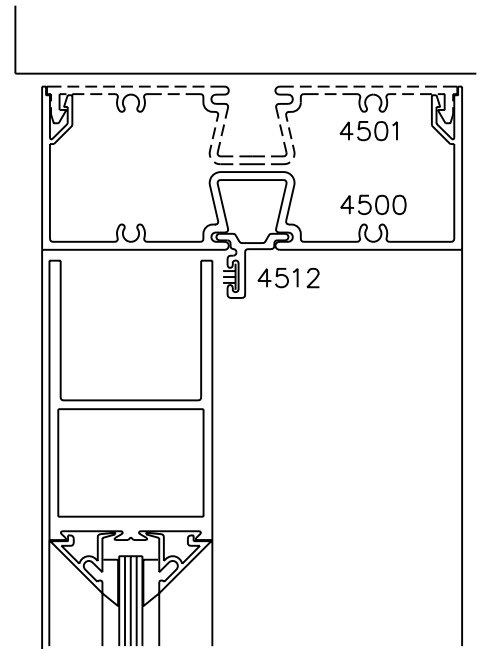

15

DOOR
HEAD

SCALE 1:2

4500 SERIES FLUSH GLAZE
for SINGLE GLAZING
45.5 mm (1.75") X 114.3 mm (4.5")

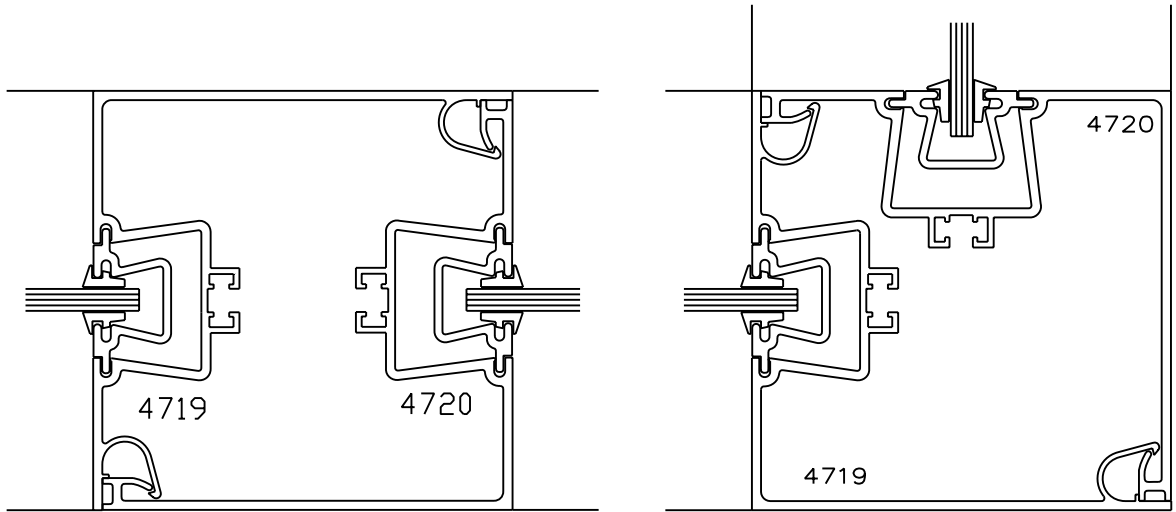

16
WIDE
MULLION

17
CORNER
MULLION

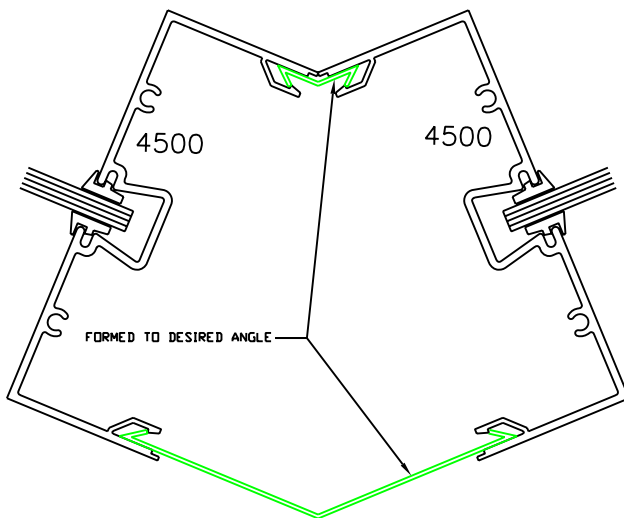

18
ANGLED
MULLION

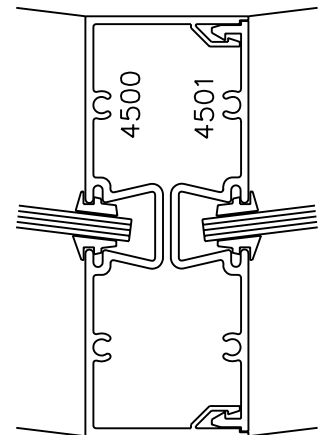

19
SEGMENTED
MULLION

SCALE 1:2

4500 SERIES FLUSH GLAZE
for SINGLE GLAZING
45.5 mm (1.75") X 114.3 mm (4.5")

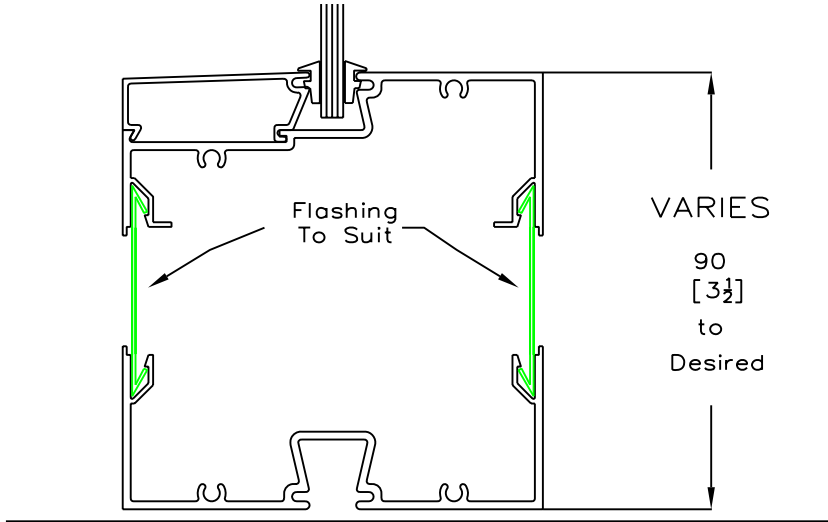

21

ADJUSTABLE
SIDE-LITE
BASE

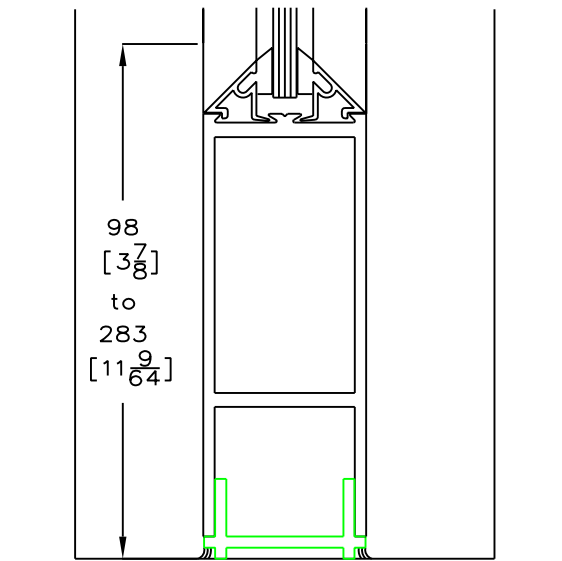

20

SIDE-LITE
BASE

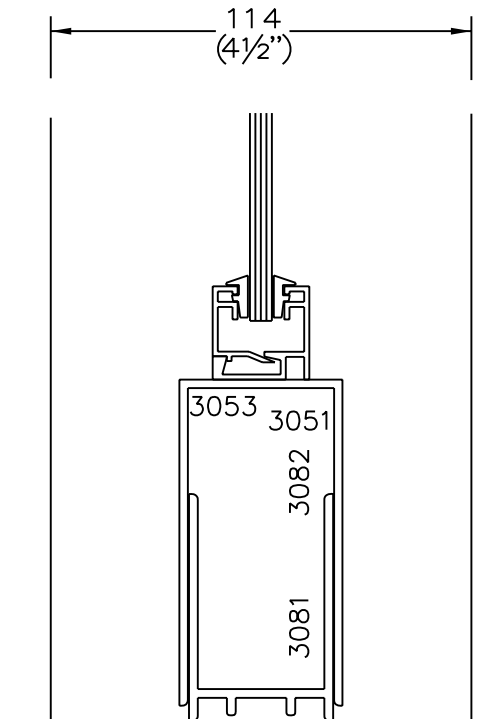

22

ADJUSTABLE
SIDE-LITE
BASE

SCALE 1:2

 **A.T. MARCK & ASSOCIATES**
BUILDING SYSTEMS ENGINEERING LTD.
TEL/FAX (604) 469-6566

PROFILE 4500 & 4501		AA 6063 T5 STL 250 W				
A= 826 mm ² I= 1321951 mm ⁴ S= 23278 mm ³		MAX. ALLOWABLE MULLION LENGTH (m/ft) FOR SPECIFIED WIND LOAD				
SPACING	0.72 kPa	0.96 kPa	1.20 kPa	1.44 kPa	1.68 kPa	1.91 kPa
	15 PSF	20 PSF	25 PSF	30 PSF	35 PSF	40 PSF
.45 m	5.00	4.55	4.20	3.95	3.75	3.60
1.5'	16.4	14.9	13.8	13.0	12.3	11.8
.60 m	4.55	4.15	3.85	3.60	3.40	3.25
2.0'	14.9	13.6	12.6	11.8	11.2	10.7
.75 m	4.20	3.85	3.55	3.35	3.10	2.90
2.5'	13.8	12.6	11.6	11.0	10.2	9.5
.90 m	3.95	3.60	3.35	3.05	2.85	2.65
3.0'	13.0	11.8	11.0	10.0	9.4	8.7
1.05 m	3.75	3.40	3.10	2.85	2.65	2.45
3.5'	12.3	11.2	10.2	9.4	8.7	8.0
1.20 m	3.60	3.25	2.90	2.65	2.45	2.30
4.0'	11.8	10.7	9.5	8.7	8.0	7.5
1.35 m	3.45	3.05	2.75	2.50	2.30	2.20
4.5'	11.3	10.0	9.0	8.2	7.5	7.2
1.50 m	3.35	2.90	2.60	2.40	2.20	2.05
5.0'	11.0	9.5	8.5	7.9	7.2	6.7
1.65 m	3.20	2.80	2.50	2.25	2.10	1.95
5.5'	10.5	9.2	8.2	7.4	6.9	6.4
1.80 m	3.05	2.65	2.40	2.15	2.00	1.90
6.0'	10.0	8.7	7.9	7.1	6.6	6.2
1.95 m	2.95	2.55	2.30	2.10	1.95	1.80
6.5'	9.7	8.4	7.5	6.9	6.4	5.9
2.10 m	2.85	2.45	2.20	2.00	1.85	1.75
7.0'	9.4	8.0	7.2	6.6	6.1	5.7
2.25 m	2.75	2.40	2.15	1.95	1.80	1.70
7.5'	9.0	7.9	7.1	6.4	5.9	5.6
2.40 m	2.65	2.30	2.05	1.90	1.75	1.65
8.0'	8.7	7.5	6.7	6.2	5.7	5.4

m
ft

- 1/ BASED ON L/175 MAX ALLOWABLE DEFLECTION
OR $F_y = 110 \text{ MPa}$ FOR AA 6063 T5
- WHICHEVER IS LESS - CONFORMING TO CAN3-S157-M83
2/ FOR ESTIMATING PURPOSES ONLY